

# TeamMate®

## Roomware Solutions



TeamMate makes life simple: with a range of truly innovative furniture solutions to suit any application. Aesthetically pleasing, modular and practical, TeamMate products are designed to stand the test of time.

## Screen Riser

MODEL: SCREENRISER

Fully retracting screen for flexible, agile & hybrid spaces in a self contained mobile enclosure.

### Features & Benefits

- >> Supports screen sizes from 55" - 65"
- >> Single or dual (back to back) screen deployment
- >> Electronic height adjustment via surface mounted switch
- >> Cable management channels
- >> Front and rear access equipment via lockable doors
- >> 1U equipment board included
- >> Interface panel for AV control panel/ input plate apertures
- >> Ergonomic base designed to enable Nesting of multiple units
- >> Can be used with TeamMate WorksZone, Kobi & Adapt Tables
- >> Grab handles for moving
- >> Black matte worktop as standard, custom colours available
- >> Black and white powdercoat paint as standard



### Overview

TeamMate Screen Riser offers complete flexibility in office or active learning environments when the focal point requires a screen. When there isn't a need for this, the user can simply remove the screen at a click of a button.

With a contemporary yet functional design, the Screen Riser comes as a single or a dual (back to back) solution that can be suited for various architectural requirements with an array of customisable options. Two grab handles allow the unit to be positioned in strategic places as well as moving aside for storage and nesting together with other units with its cleverly designed base.



ACTIVE LEARNING CLASSROOM WITH SCREEN RISER AND KOBİ TABLES - SCREENS DOWN FOR IMPROVED SIGHTLINES



ACTIVE LEARNING CLASSROOM WITH SCREEN RISER AND KOBİ TABLES - SCREENS UP FOR 'COLLABORATION'

## Screen Riser technical specifications:

- >> Compatible with single or dual (back to back) screens 55-65"
- >> Electronic height adjustment via x2 actuator lifting columns
- >> Internal cable management chains
- >> 1U peg board included for vertically mounting equipment
- >> x2 grab handles included on each side
- >> Locking castors
- >> Standard worktop colour of black matte
- >> Standard metalwork colours of black & white powdercoat paint



Single 55" screen



Back to back 55" screens only

### Additional cost options:

- >> Custom worktop colour
- >> Custom interface panel
- >> Power bar module
- >> Sound bar bracket (55" only)
- >> Castor upgrade kit (100mm castors)



Multiple units nesting

### Standard metalwork finishes:

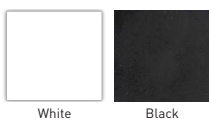

White Black

### Non-Standard metalwork finishes:

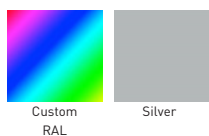

Custom RAL Silver



Castor Upgrade Kit



Single 65" screen

SCREEN RISER  
TECHNICAL DRAWINGS

Standard Castor 55":

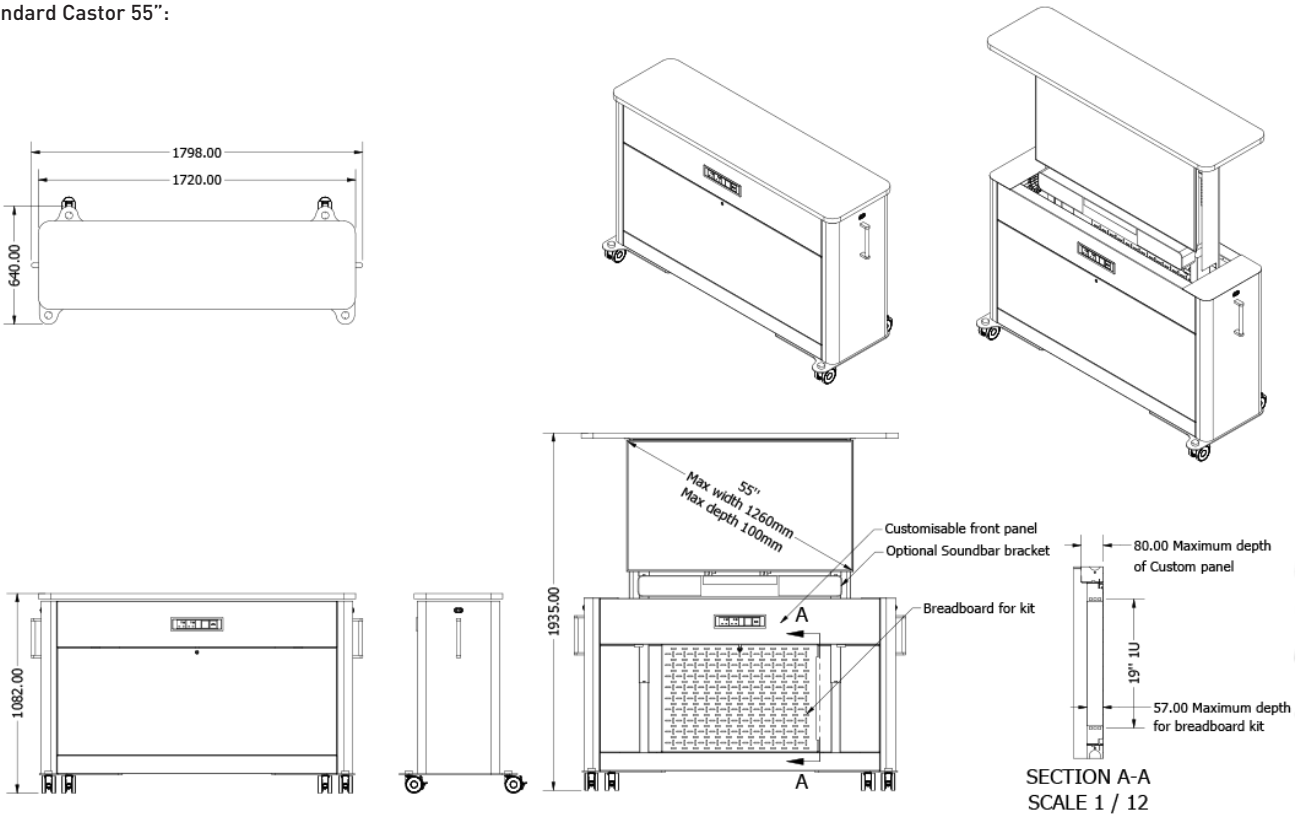

SCREEN RISER  
TECHNICAL DRAWINGS

Standard castor 65":

