



TeamMate makes life simple: with a range of truly innovative furniture solutions to suit any application. Aesthetically pleasing, modular and practical, TeamMate products are designed to stand the test of time.

Mobi Screen Stand (Tilt)

MODEL: MOBILTILT

Low cost, mobile and contemporary electronically height adjustable screen stand for lightweight displays

Features & Benefits

- >> Electronic height and tilt adjustment
- >> Fits through standard doorways
- >> Mobile with lock-down castors
- >> Equality act compliant for wheelchair access
- >> Low cost screen stand
- >> Max lifting weight 70kg
- >> Simple cable management
- >> Upper compartment with power block
- >> Lower compartment for cable management
- >> Cable management cable snake included
- >> Includes cut-out grab handles for manoeuvring around office/ workspace
- >> Finished in white powdercoat paint
- >> VESA mounting bars easy to remove and secured in place
- >> 3 year return to base warranty



Overview

Mobi Tilt is a contemporary looking, electric height and tilt adjusting screen stand for displays up to 80" in size and 70kg in weight.

Its compact design enables Mobi to be manoeuvred between spaces with ease and it has an upper and lower compartment to store a power block and cable management if necessary.

The ergonomic design of Mobi allows for use between various spaces, allowing you to collaborate and take the meeting with you.

Mobi Tilt technical specifications:

- >> 4 mobile locking castors
- >> Dual lifting and tilting actuators electrically operated. Maximum lifting weight (including screen) 70kg and 80" in size
- >> Height adjustment range of 855 - 1500mm
- >> VESA mounting pattern: 100x100 - 800x600mm
- >> Upper level enclosure for an cable management and power block
- >> Lower level cable compartment
- >> 90 degrees of tilt
- >> Internal 4 way IEC block
- >> Standard storage enclosure 630W x 250D x 410Hmm
- >> Screen not included

Optional Extras:

- >> Power bar module
(x2 UK power with x2 grommets)

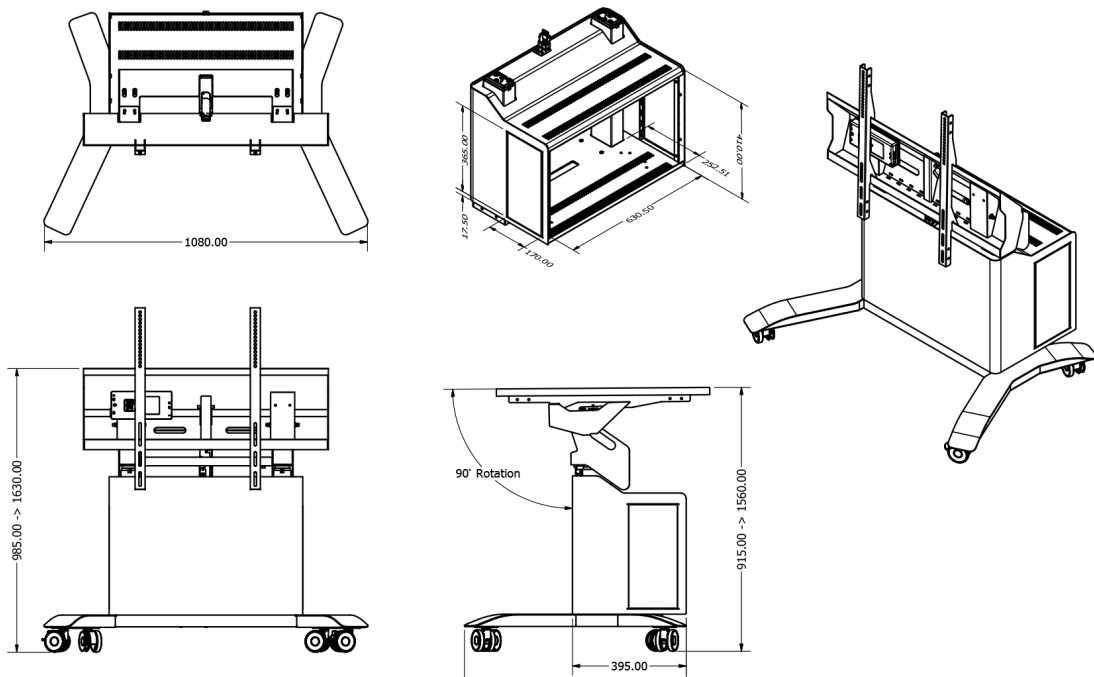

Headquarters

TeamMate

EMEA

7 Rockfort Industrial Estate
Hithercroft Road
Wallingford, Oxfordshire
OX10 9DA
United Kingdom

T: +44 (0) 1491 825739

F: +44 (0) 1491 838568

E: info@teammateworld.com

W: www.teammateworld.com

Date of issue October 2020 v1.3

These specifications are subject to change.
E&OE.

TeamMate is a registered trademark of
Performance Enclosures Ltd.