

# TeamMate®

## Roomware Solutions



TeamMate makes life simple: with a range of truly innovative furniture solutions to suit any application. Aesthetically pleasing, modular and practical, TeamMate products are designed to stand the test of time.

## Mobi Screen Stand

MODEL: MOBISTD

Low cost, mobile and contemporary electronically height adjustable screen stand for lightweight displays

### Features & Benefits

- >> Electronic height adjustment
- >> Fits through standard doorways
- >> Mobile with lock-down castors
- >> Equality act compliant for wheelchair access
- >> Low cost screen stand
- >> Max lifting weight 95kg
- >> Simple cable management
- >> Upper compartment with power block
- >> Includes cut-out grab handles for manoeuvring around office/ workspace
- >> Finished in white powdercoat paint
- >> VESA mounting bars easy to remove and secured in place
- >> Spiral cord height adjustment handset
- >> 3 year return to base warranty



### Overview

Mobi is a contemporary looking, low-cost screen stand for displays up to 86" in size and 95kg in weight.

Its compact design enables Mobi to be manoeuvred between spaces with ease and it has an upper compartment to storage for a power block.

The ergonomic design of Mobi allows for use between various spaces, allowing you to collaborate and take the meeting with you.

## Mobi Screen Stand technical specifications:

- >> 4 mobile locking castors
- >> Upper level enclosure for an cable management and power block
- >> Dual lifting actuators electrically operated. Maximum lifting weight (including screen) 95kg and 86"
- >> Height adjustment range of 930 - 1575mm
- >> Internal 4 way IEC block
- >> VESA mounting pattern: 800x600mm



### Additional cost options:

- >> Sound bar mounting bracket
- >> VC camera shelf

### Standard metalwork finishes:



White

### Added cost metalwork finishes:

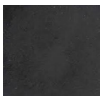

Black



Silver



Custom  
RAL



## MOBI SCREEN STAND TECHNICAL DRAWING

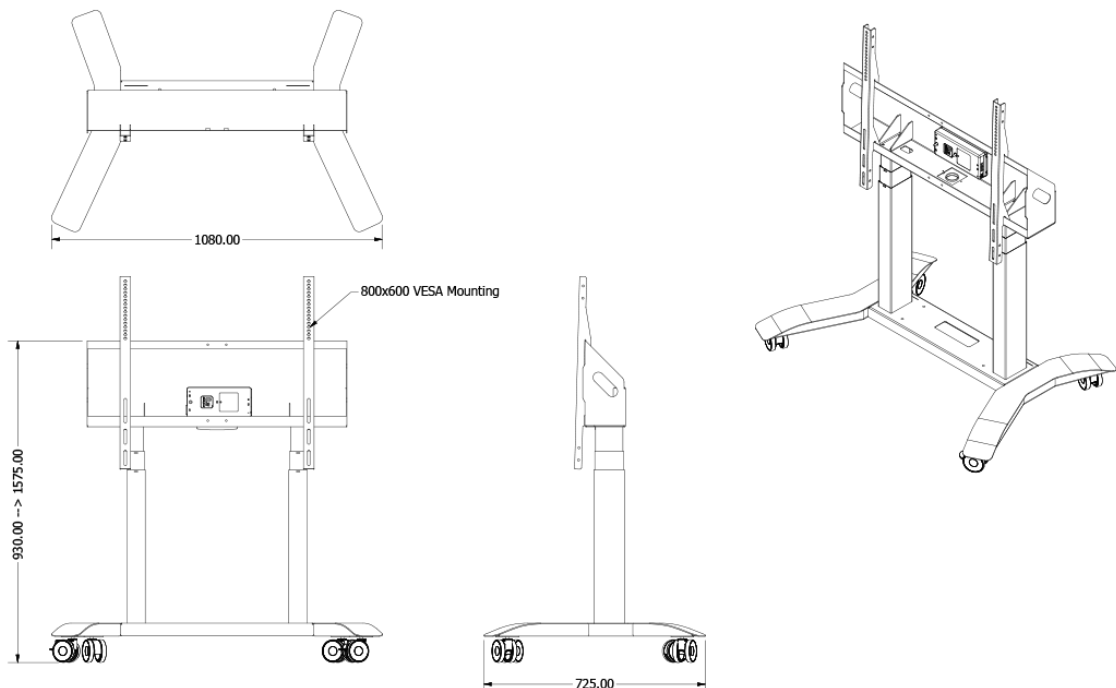

# TeamMate®

## Roomware Solutions



TeamMate makes life simple: with a range of truly innovative furniture solutions to suit any application. Aesthetically pleasing, modular and practical, TeamMate products are designed to stand the test of time.

## Mobi Screen Stand w/ Storage

MODEL: MOBISTORAGE

Low cost, mobile and contemporary electronically height adjustable screen stand for lightweight displays with storage module

### Features & Benefits

- >> Electronic height adjustment
- >> Fits through standard doorways
- >> Mobile with lock-down castors
- >> Equality act compliant for wheelchair access
- >> Low cost screen stand
- >> Max lifting weight 95kg
- >> Full cable management
- >> Upper compartment with power block
- >> Lower compartment for compact PC and/or rack module
- >> Includes cut-out grab handles for manoeuvring around office/ workspace
- >> Finished in white powdercoat paint
- >> VESA mounting bars easy to remove and secured in place
- >> Spiral cord height adjustment handset
- >> 3 year return to base



### Overview

Mobi is a contemporary looking, low-cost screen stand for displays up to 86" in size and 95kg in weight.

Its compact design enables Mobi to be manoeuvred between spaces with ease and it has an upper and lower compartment to storage for a power block that is fully cable managed.

The ergonomic design of Mobi allows for use between various spaces, allowing you to collaborate and take the meeting with you.

## Mobi Screen Stand technical specifications:

- >> 4 mobile locking castors
- >> Upper level enclosure for an cable management and 4 way IEC power block
- >> Dual lifting actuators electrically operated. Maximum lifting weight (including screen) 95kg and 86"
- >> Height adjustment range of 930 - 1575mm
- >> Lower level storage module for PC
- >> VESA mounting pattern: 800x600mm

### Additional cost options:

- >> 19" 6U x 325mm slide-out equipment rack
- >> Power module
- >> Sound bar mounting bracket
- >> VC/ housing shelf
- >> Control housing

### Standard metalwork finishes:

### Added cost metalwork finishes:



White

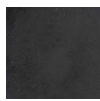

Black



Silver



Custom  
RAL



## MOBI SCREEN STAND W/STORAGE TECHNICAL DRAWING

