

| Rev | Description | Date | Name |
|-----|------------------------|----------|--------|
| - | - | - | - |
| A | Issued for manufacture | 08/11/21 | S.Hack |

Notes:
 General Tolerance ± 0.2
 Angular Tolerance ± 0.5
 Hole Position ± 0.2
 Unless otherwise stated all dimensions are in millimetres
 Remove all sharp edges to BS308: 1984 Parts 1,2 and 3.

DO NOT SCALE IF IN DOUBT ASK

THIS DRAWING IS THE PROPERTY OF PERFORMANCE ENCLOSURES LIMITED AND THE INFORMATION CONTAINED HEREIN IS CONFIDENTIAL. THE DRAWING MAY NOT BE COPIED, USED OR DISCLOSED EXCEPT WITH WRITTEN PERMISSION OF AND IN THE MANNER PERMITTED BY THE PROPRIETORS.

| | |
|-----------|--------|
| Material: | - |
| Finish: | - |
| Drawn: | S.Hack |
| Checked: | - |
| Approved: | - |
| Scale: | 1 / 14 |

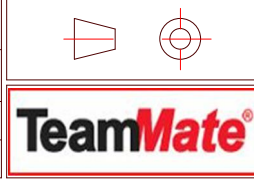

| | |
|----------------|-----------------------|
| Drawing Title: | Adapt - Folding table |
| Drawing No.: | - |
| Sheet 1 of 2 | |

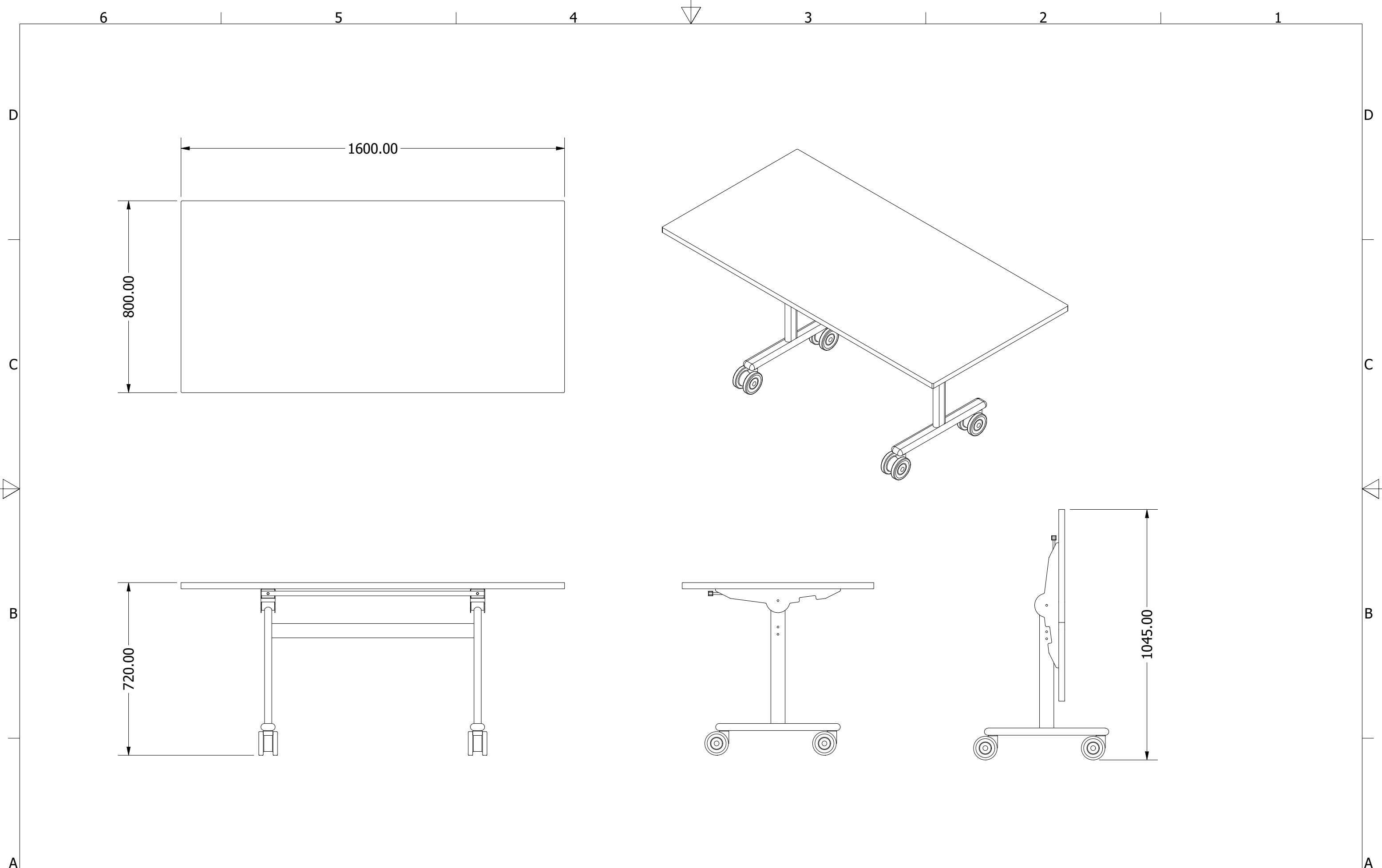

| Rev | Description | Date | Name |
|-----|------------------------|----------|--------|
| - | - | - | - |
| A | Issued for manufacture | 08/11/21 | S.Hack |

Notes:
 General Tolerance ± 0.2
 Angular Tolerance ± 0.5
 Hole Position ± 0.2
 Unless otherwise stated all dimensions are in millimetres
 Remove all sharp edges to BS308: 1984 Parts 1,2 and 3.

DO NOT SCALE IF IN DOUBT ASK

THIS DRAWING IS THE PROPERTY OF PERFORMANCE ENCLOSURES LIMITED AND THE INFORMATION CONTAINED HEREIN IS CONFIDENTIAL. THE DRAWING MAY NOT BE COPIED, USED OR DISCLOSED EXCEPT WITH WRITTEN PERMISSION OF AND IN THE MANNER PERMITTED BY THE PROPRIETORS.

| | |
|-----------|--------|
| Material: | - |
| Finish: | - |
| Drawn: | S.Hack |
| Checked: | - |
| Approved: | - |
| Scale: | 1 / 14 |

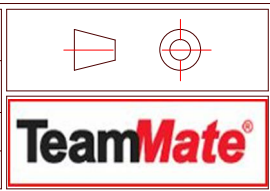

| | |
|----------------|-----------------------|
| Drawing Title: | Adapt - Folding table |
| Drawing No.: | - |
| Sheet 2 of 2 | |